

50HZ



0.5~3HP Sub.ejector pump

Optional  
TOS-EFJ  
Sub.Ejector pump with  
guide rail device  
(0.5~3HP)



5~7.5HP Sub.ejector pump

Optional  
TOS-EFJ  
Sub.Ejector pump with  
guide rail device  
(5~7.5HP)

### ▲ Features

- All models adopt silicon carbide(SiC) dual mechanical seals to ensure best seal effect and reduce abrasion from wastewater
- High oxygen transfer rate, BOD easy to remove from wastewater treatment.
- Mixing and stirring applications for uniform MLSS due to fine bubbles convention.

### ▲ Motor Spec.

- 2P dry type motor, with overload protector.
- Insulation: F class.
- Protection: IP68.
- Frequency: 50HZ.
- Voltage: 1Phase(0.5~2HP); 3Phase(All models).

### ▲ Parts and Materials List

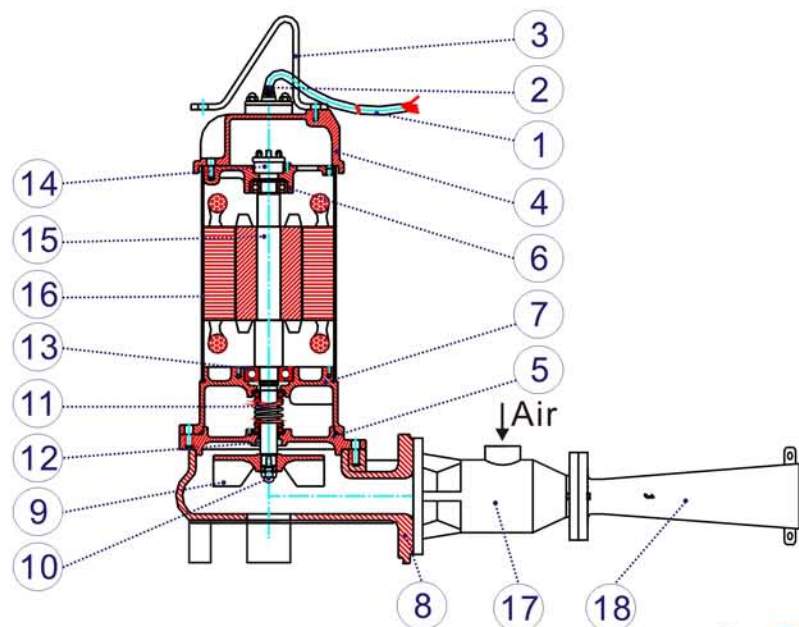

### ▲ Applications

- Oxygen aeration of wastewater for wastewater treatment. Oxygenated for aquaculture such as fish, shrimp farming or hydroponics applications.

### ▲ Model Code

TOS-EFJ-20(T)

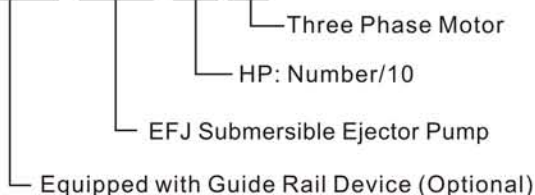

No.	Parts	Std. Material
1	Cable	STOW or VCT
2	Cable hood	PVC
3	Handle	Nylon66(0.5~1HP);SS400
4	Motor cover	Nylon66(0.5HP) ; FC200
5	Seal housing	FC200
6	Bracket	FC200
7	Oil chamber	FC200
8	Pump casing	FC200
9	Impeller	FC200
10	Nut	SUS304
11	Mech. seal	SiC/SiC
12	Oil seal	NBR
13	Bearing	(NTN brand)
14	Overload protector	(T.I.brand)
15	Shaft	SUS410
16	Motor housing	SUS304
17	Ejector-Mix chamber	FC200
18	Ejector-Diffuser	FC200

### Performance Curves

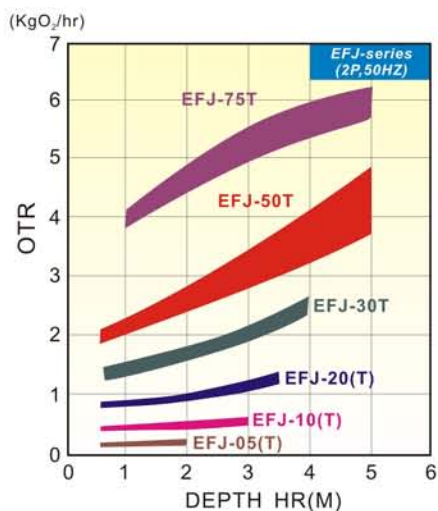
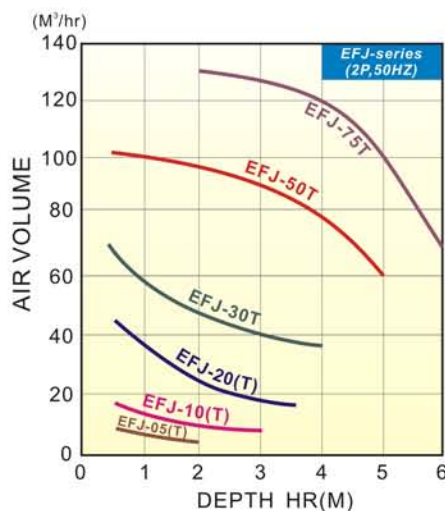

### Performance Tables

Model	HP	Rated performance			Suit aeration Tank		
		Air (M <sup>3</sup> /hr)	OTR (KgO <sub>2</sub> /hr)	HR (M)	L (M)	W (M)	H (M)
EFJ-05(T)	0.5	5	0.12~0.23	1.5	2.0	1.8	2.0
EFJ-10(T)	1	10	0.3~0.5	2.0	3.0	2.5	3.0
EFJ-20(T)	2	22	0.9~1.1	2.5	4.0	3.5	3.5
EFJ-30T	3	40	1.9~2.2	3.0	5.0	4.5	4.0
EFJ-50T	5	85	3.0~3.8	3.5	6.0	5.0	5.0
EFJ-75T	7.5	120	4.2~5.2	4.0	7.0	6.0	6.0

Remarks: ● (T): Three phase motor

### Dimensions

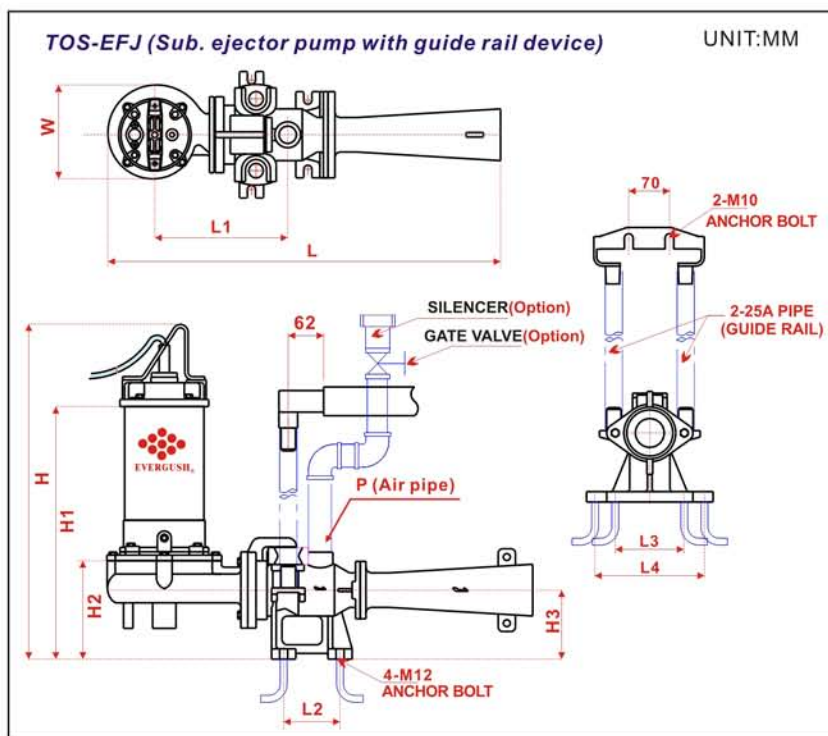
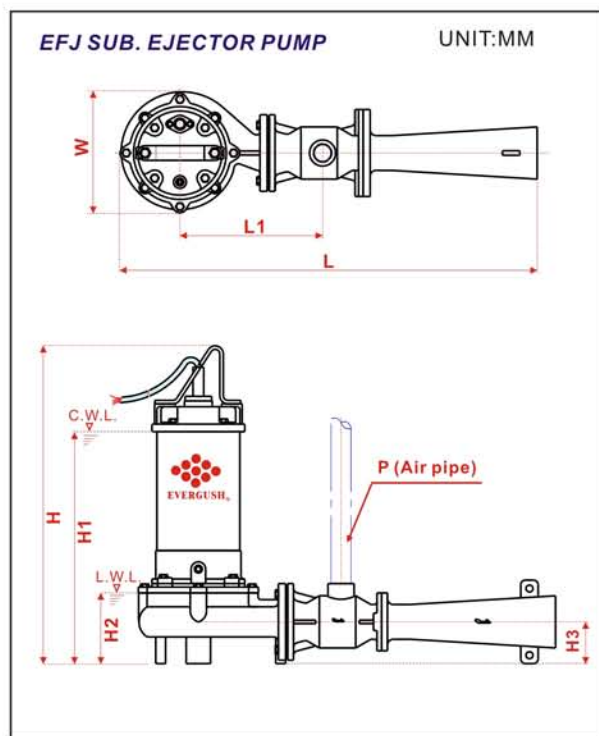

### EFJ Dimension Tables

Model	HP	Dimensions (MM)								Net Weight Kg
		L	L1	W	H	H1	H2	H3	P	
EFJ-05(T)	0.5	649	197	163	417	304	120	72	25A	23
EFJ-10(T)	1	649	197	163	471	347	120	72	25A	31
EFJ-20(T)	2	719	246	208	548	400	122	72	40A	40
EFJ-30T	3	719	246	208	568	420	122	72	40A	42
EFJ-50T	5	769	290	227	633	468	160	92	50A	68
EFJ-75T	7.5	769	290	227	673	508	160	92	50A	74

Remarks: ● (T): Three phase motor.

### TOS-EFJ Dimension Tables

Model	HP	Dimensions (MM)											Net Weight Kg
		L	L1	L2	L3	L4	W	H	H1	H2	H3	P	
TOS-EFJ-05(T)	0.5	683	231	98	120	190	163	465	352	168	120	25A	33
TOS-EFJ-10(T)	1	683	231	98	120	190	163	519	395	168	120	25A	41
TOS-EFJ-20(T)	2	753	280	98	120	190	208	596	448	170	120	40A	50
TOS-EFJ-30T	3	753	280	98	120	190	208	616	468	170	120	40A	52
TOS-EFJ-50T	5	983	480	160	150	---	227	749	579	280	200	50A	82
TOS-EFJ-75T	7.5	983	480	160	150	---	227	789	619	280	200	50A	88

Remarks: ● (T): Three phase motor.