



Product Features:

50HZ 60HZ

- Through simple and convenient installation, we can connect the pump onto guide rail device. Whenever the pump needs maintenance, it can be easily pulled out through guide bar to dismantle, repair or examine the pump. For safety purpose, The workers no longer need to go down the septic tank to do maintenance. It will greatly reduce down time.

Applications:

- Animal husbandry and dairying septic tank waste water drainage; sewers, apartments, buildings and basements sewage treatment equipment drainage; Dye house, fur and leather industry and steel industry waste water drainage; other waste water treatments drainage.

Installation Diagram:

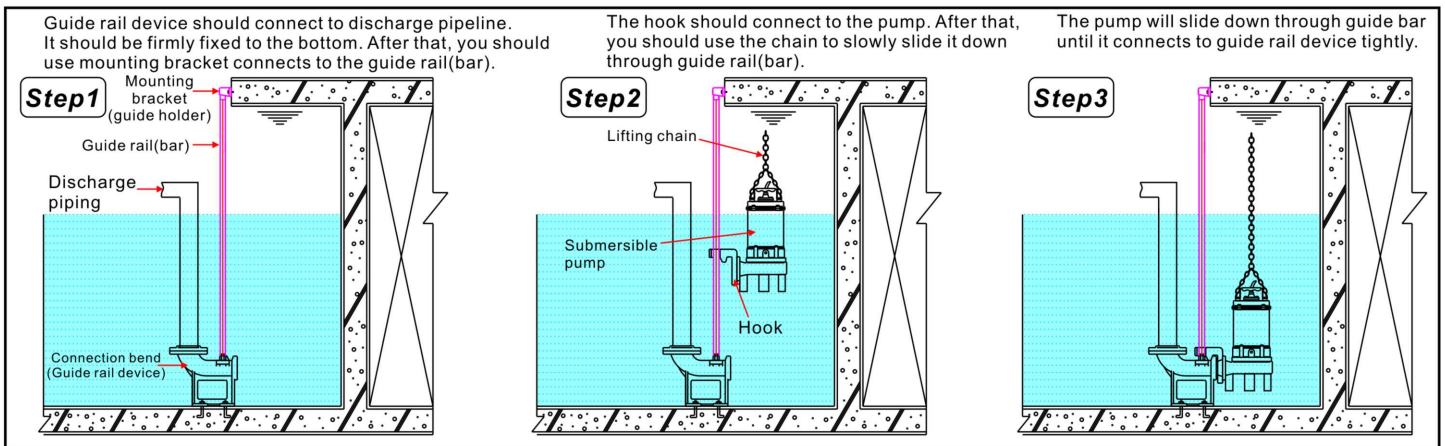

Dimensions:

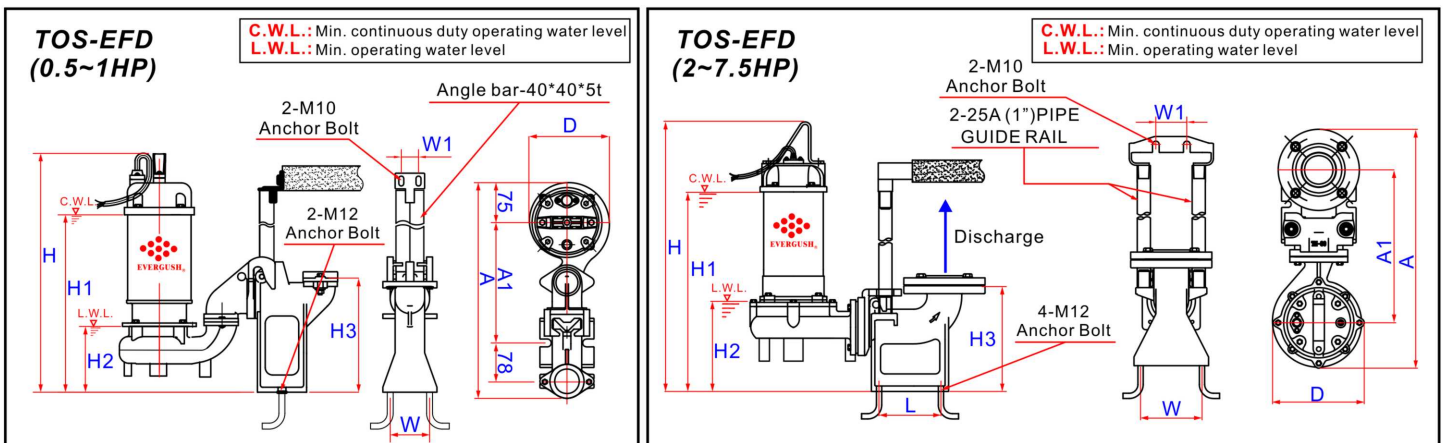

Model	Power	Disch. Inch	Dimensions(mm)										Weight(KG)	
	HP		A	A1	D	H	H1	H2	H3	L	W	W1	TOS Device	TOS & PUMP
TOS-EFD-05(T)	0.5	2"	425	240	150	422	307	150	225	---	80	35	6	19
TOS-EFD-10(T)	1	2"	425	240	150	502	377	150	225	---	80	35	6	24
TOS-EFD-20(T)	2	3"	545	350	210	650	480	210	243	110	140	70	16	49
TOS-EFD-30T	3	3"	545	350	210	670	500	210	243	110	140	70	16	51
TOS-EFD-50T	5	4"	725	515	230	745	580	270	310	160	150	70	24	79
TOS-EFD-75T	7.5	4"	725	515	230	785	620	270	310	160	150	70	24	85

Remarks: ● TOS means cast iron guide rail device. (Q.D.C:Quick Discharge Device) ● "T" means 3 phase motor.