



2~3HP Sub.ejector pump



5~7.5HP Sub.ejector pump

### ▲ Features

- All models adopt silicon carbide(SIC) dual mechanical seals to ensure best seal effect and reduce abrasion from wastewater
- High oxygen transfer rate, BOD easy to remove from wastewater treatment.
- Mixing and stirring applications for uniform MLSS due to fine bubbles convention.

### ▲ Motor Spec.

- 2P dry type motor, with overload protector.
- Insulation: F class.
- Protection: IP68.
- Frequency: 50HZ.
- Voltage: 1Phase(0.5~2HP); 3Phase(All models).

### ▲ Parts and Materials List

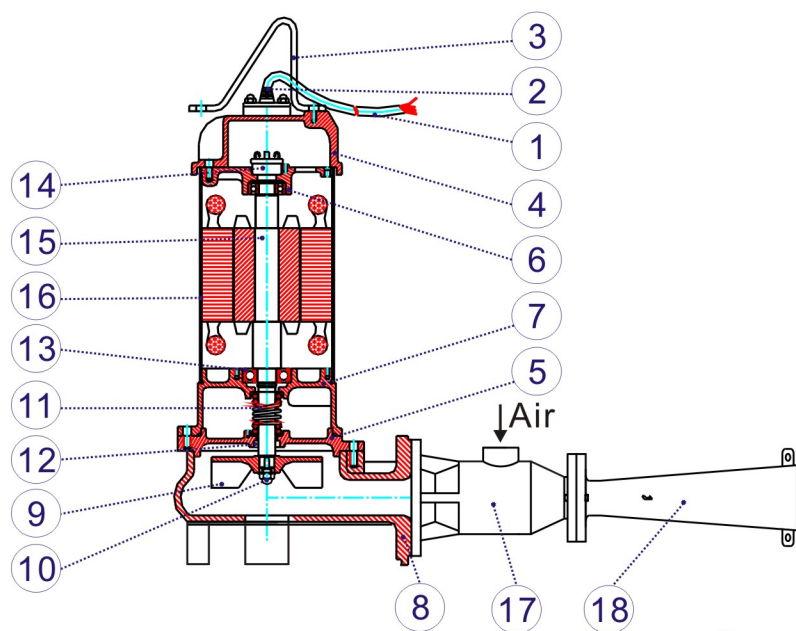

### ▲ Applications

- Oxygen aeration of wastewater for wastewater treatment. Oxygenated for aquaculture such as fish, shrimp farming or hydroponics applications.

### ▲ Model Code

**TOS-EAFJ-20(T)**

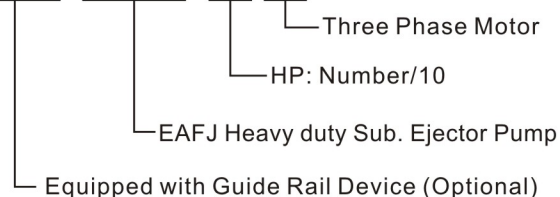

No.	Parts	Std. Material
1	Cable	STOW or VCT
2	Cable hood	PVC
3	Handle	SS400
4	Motor cover	FC200
5	Seal housing	FC200
6	Bracket	FC200
7	Oil chamber	FC200
8	Pump casing	FC200
9	Impeller	FC200
10	Nut	SUS304
11	Mech. seal	SIC/SIC
12	Oil seal	NBR
13	Bearing	(NTN brand)
14	Overload protector	(T.I.brand)
15	Shaft	SUS410
16	Motor housing	FC200
17	Ejector-Mix chamber	FC200
18	Ejector-Diffuser	FC200

### ▲ Performance Curve

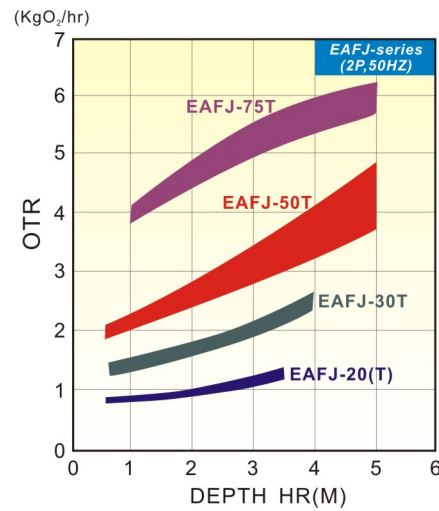
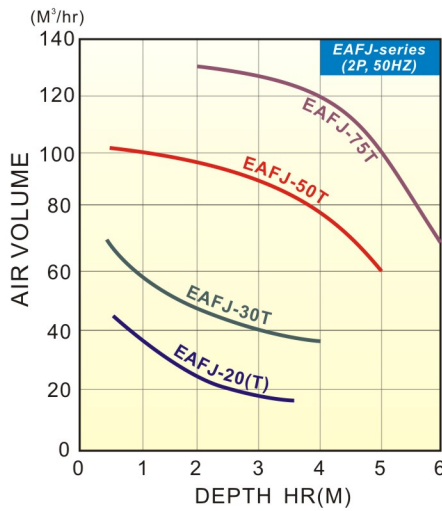

### ▲ Performance Table

Model	HP	Rated performance			Suit aeration Tank		
		Air (M <sup>3</sup> /hr)	OTR (KgO <sub>2</sub> /hr)	HR (M)	L (M)	W (M)	H (M)
EAFJ-20(T)	2	22	0.9~1.1	2.5	4.0	3.5	3.5
EAFJ-30T	3	40	1.9~2.2	3.0	5.0	4.5	4.0
EAFJ-50T	5	85	3.0~3.8	3.5	6.0	5.0	5.0
EAFJ-75T	7.5	120	4.2~5.2	4.0	7.0	6.0	6.0

Remarks: ● (T): Three phase motor

### ▲ Dimension

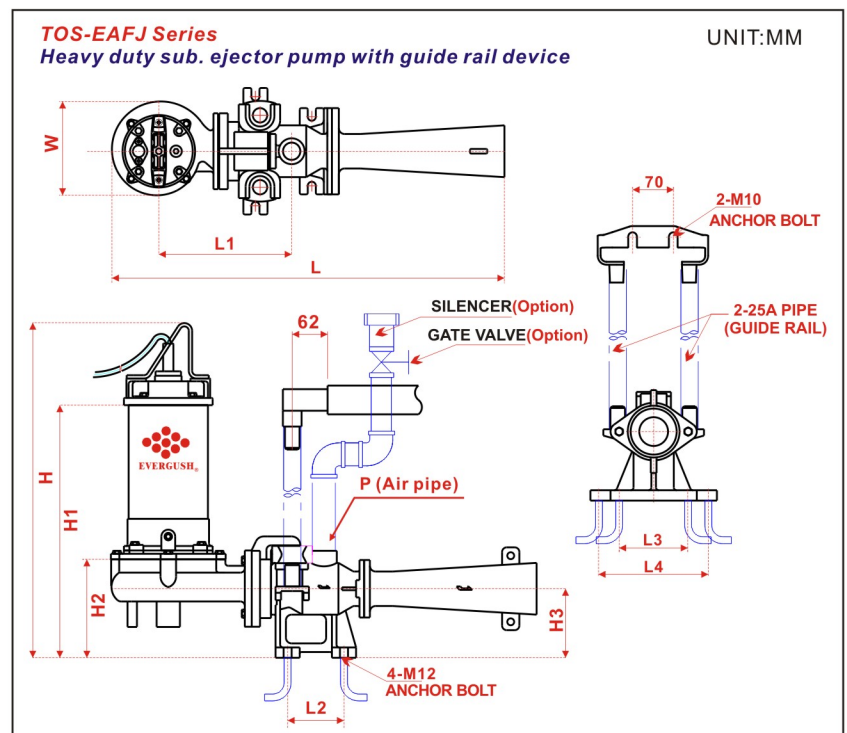
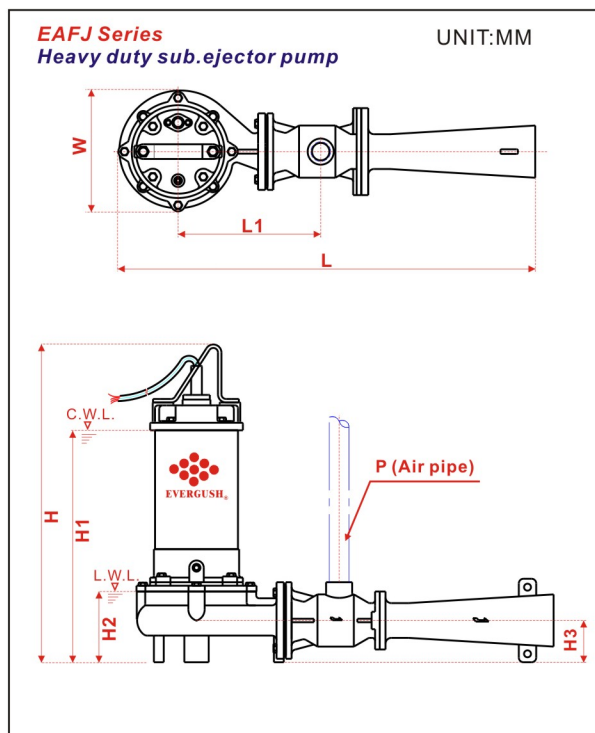

### ● EAFJ Dimension Table

Model	HP	Dimensions (MM)								Net Weight Kg
		L	L1	W	H	H1	H2	H3	P	
EAFJ-20(T)	2	719	246	208	548	400	122	72	40A	40
EAFJ-30T	3	719	246	208	568	420	122	72	40A	42
EAFJ-50T	5	769	290	227	633	468	160	92	50A	68
EAFJ-75T	7.5	769	290	227	673	508	160	92	50A	74

Remarks: ● (T): Three phase motor.

### ● TOS-EAFJ Dimension Table

Model	HP	Dimensions (MM)											Net Weight Kg
		L	L1	L2	L3	L4	W	H	H1	H2	H3	P	
TOS-EAFJ-20(T)	2	753	280	98	120	190	208	596	448	170	120	40A	50
TOS-EAFJ-30T	3	753	280	98	120	190	208	616	468	170	120	40A	52
TOS-EAFJ-50T	5	983	480	160	150	---	227	749	579	280	200	50A	82
TOS-EAFJ-75T	7.5	983	480	160	150	---	227	789	619	280	200	50A	88

Remarks: ● (T): Three phase motor.